

Technical data

	Operating through hot water exchanger		Operating through accumulation system	
	Certified values	Larger batch of wood	Operating values	
Energy label	A+			
Operating data				
Nominal heat power / Power absorbed to water	14,5 / 10,9 kW	25,5 / 14,3 kW	----	----
Efficiency	>85 %	>85 %	----	----
Consumption of wood	3,7 kg/h	6,8 kg/h	6 kg	15 kg
Total heat output of the burning chamber	----	----	24 kW	60 kW
Average heat output / heat accumulation time ⁵	----	----	2,4 kW / 8 h	4 kW / 12 h
Mass flow of flue gas	11,7 g/s	18,1 g/s	18 g/s	45 g/s
Required chimney pressure	15 Pa	15 Pa	15 Pa	15 Pa
Required amount of combustion air	35 m ³ /h	60 m ³ /h	55 m ³ /h	130 m ³ /h
Average flue gas temperature				
on the output (behind water exchanger)	168 °C	197 °C	----	----
on the output (in front of accumulation mass)	----	----	378 °C	616 °C
behind 3,5 m of ceramic accumulation system KMS 300	----	----	185 °C	
behind 5,5 m of ceramic accumulation system KMS 300	----	----	----	178 °C
Heat distribution				
heating insert	10%	21%	10%	15%
door glass (double)	14%	14%	14%	14%
water	76%	65%	15%	18%
additional accumulation mass	----	----	61%	53%
Water exchanger specifications				
Maximum working pressure	2,5 bar			
Minimum return water temperature	60 °C			
Water capacity	80 liters			
Minimal pump output	15 l/min			
Connection input / output	1" / 1"			
Information for builds				
Minimal grill area supply / outgoing (with vent. grill)	600 / 700 cm ²			
Minimum radiant area ³ (without vent. grill)	suitable		8 m ²	
Minimum distance from insulated areas / floor	40 / 20 mm			
Reference insulation ¹ ceiling / back wall / side wall / floor	120 / 100 / 80 / 30 mm			
Calciumsilicate insulation ² ceiling / back wall / side wall / floor	90 / 75 / 60 / 30 mm			
General technical information				
Total weight / lining weight	circa 400 / 120 kg			
Burning chamber dimensions (width x depth)	305 x 525 mm			
Combustion air connection	Ø 150 mm			
Use in non-ventilated accumulation builds according to craft rules	suitable ⁴			
Tested according to	EN 13229			
Meets values	1. BImSchV (Stufe2), 15a BVG			

1 Mineral wool according to AGI-Q 132

2 Example SkamoEnclosure Board 225 kg/m³

3 Depends on accumulation period and material characteristics. Listed values calculated with average specific heat output = approx. 500 W/m²

4 With regard to the inspection capability and maximum ambient temperatures of the external switching devices (e.g. TAS/SV)

5 Storage operation, one wood charge for storage duration, with closed construction and efficiency > 80%

WHE 37/50

Technical data
Version 09/2023

WHE 37/50 air inlet / feet

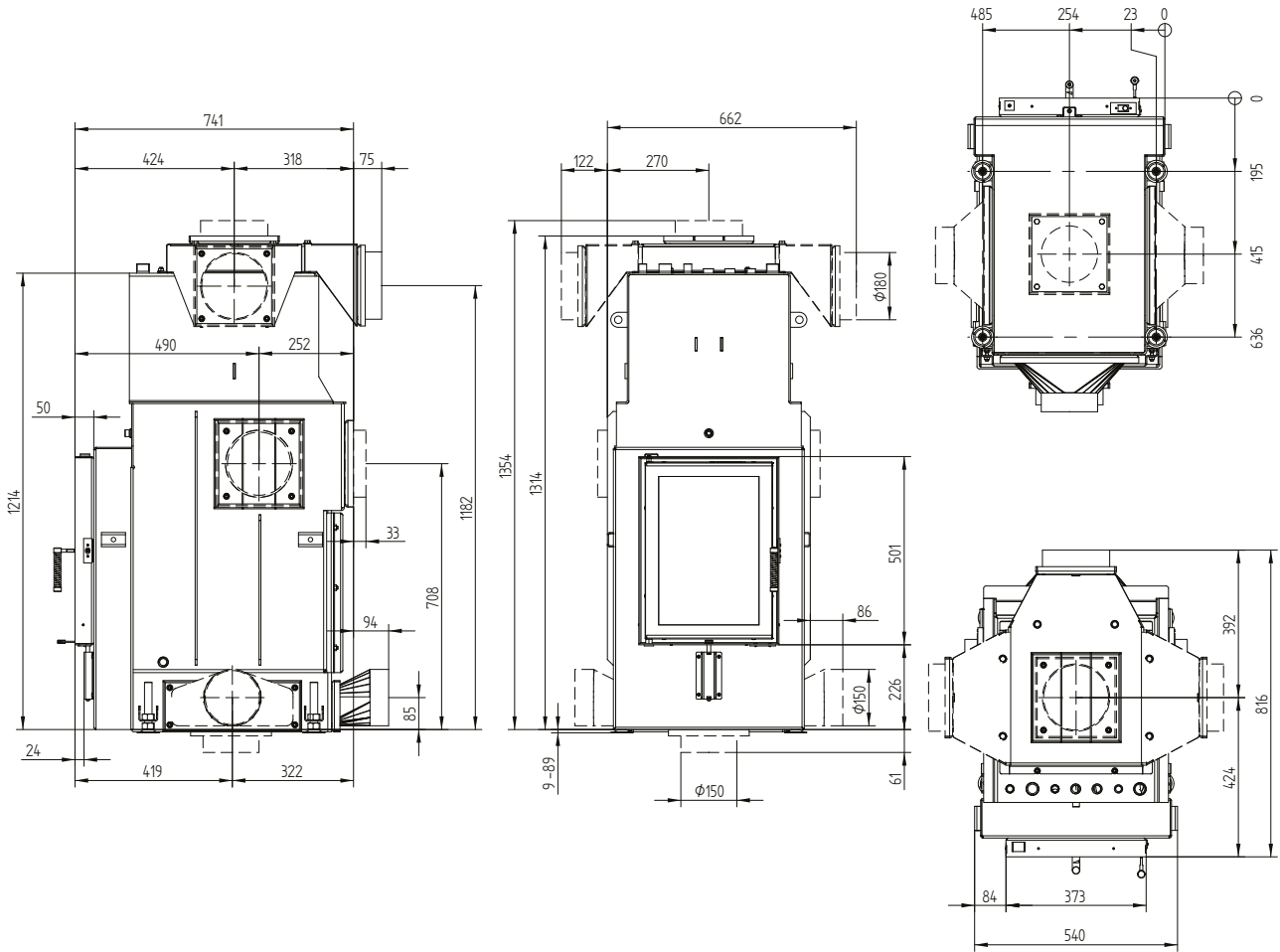

WHE 37/50WTR water exchanger cleaner

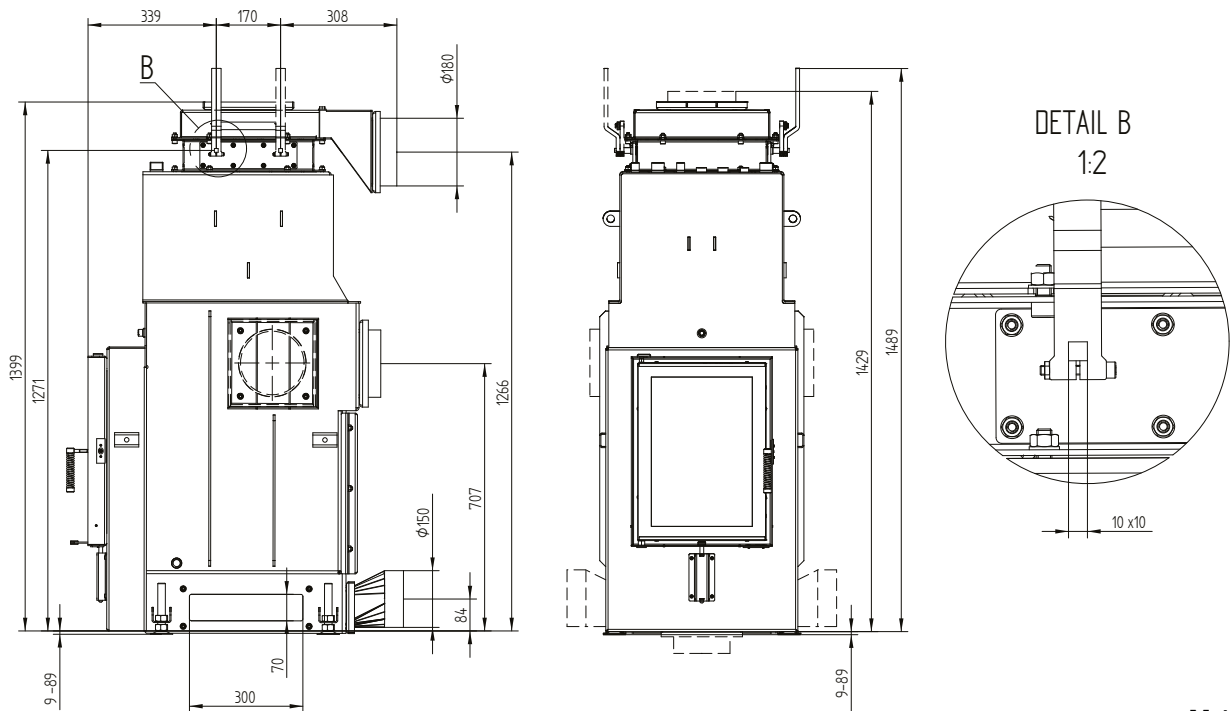

WHE 37/50

Technical data
Version 09/2023

WHE 37/50 Cover frame 4sides 50 mm 1 x 90°

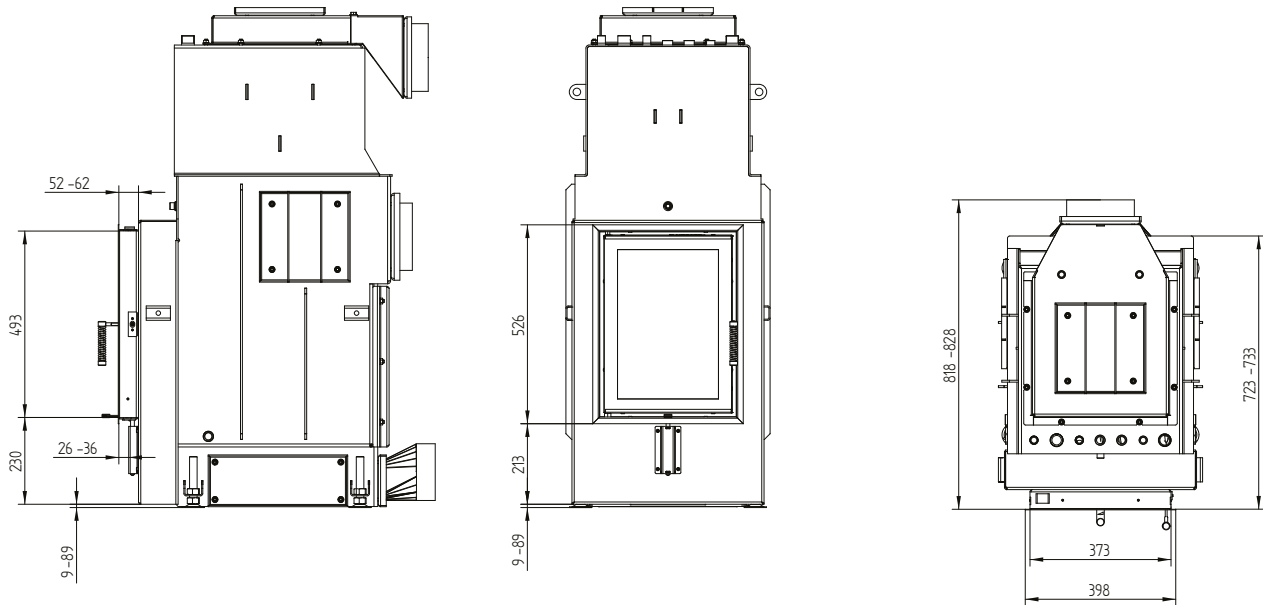

WHE 37/50 Cover frame 4sides 80 mm 2 x 45°

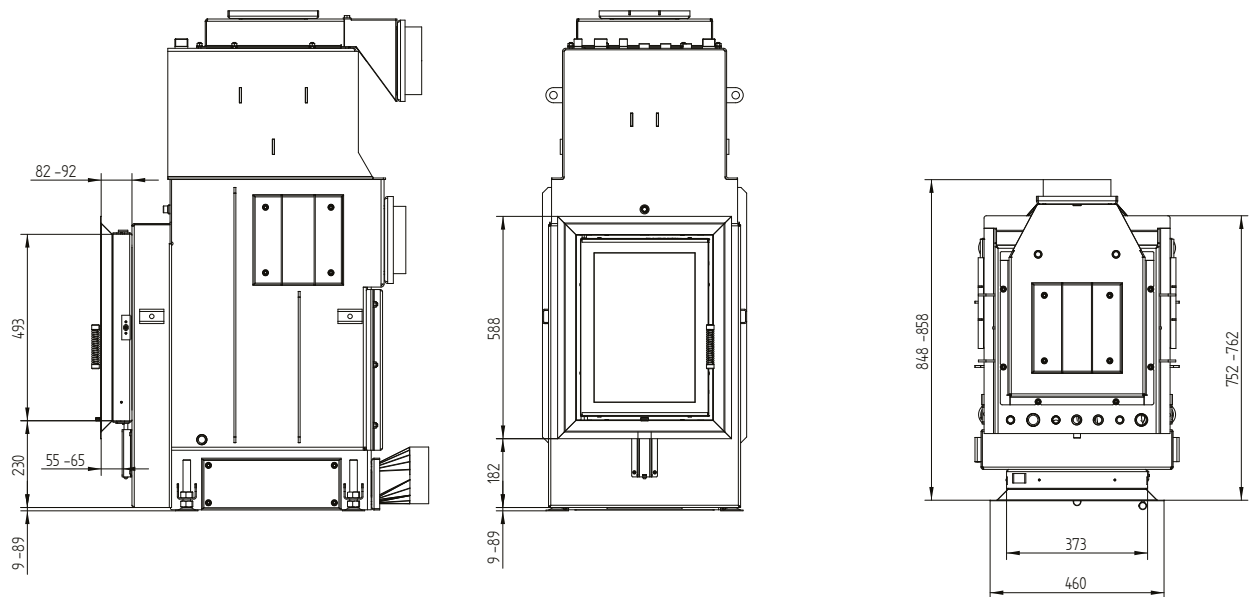

WHE 37/50 | WHE 37/50 WTR water exchanger cleaner

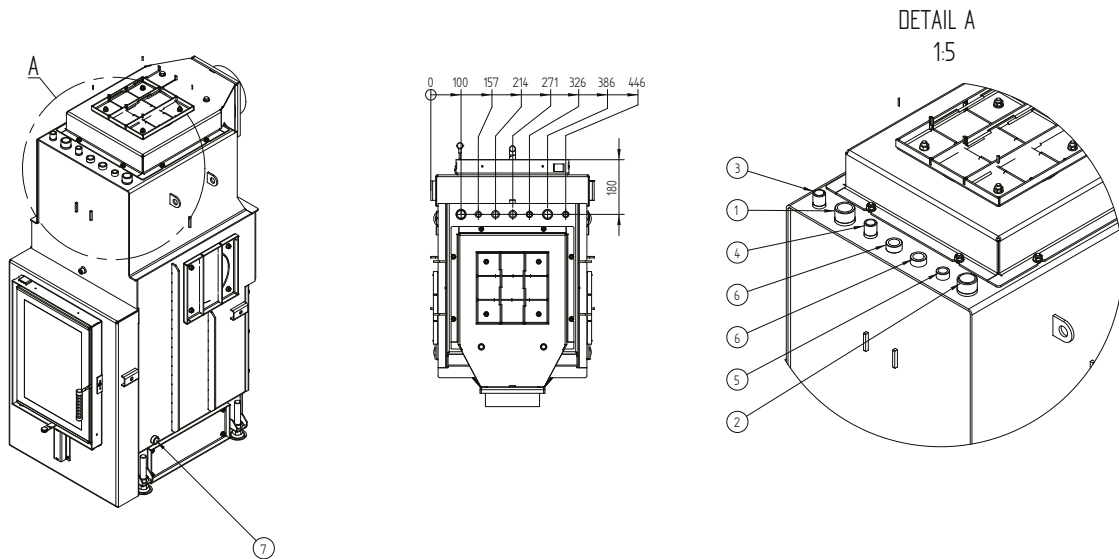

Nr.	Thread size	Description
1	G 1" (AG)	Water supply from heating system – min. 60°C
2	G 1" (AG)	Hot water supply to heating system
3	G 1/2" (AG)	Water supply from the waterlines into the cooling loop
4	G 1/2" (AG)	Discharge of water from the cooling loop into the waste
5	G 3/8" (IG)	Pocket for air vent valve
6	G 1/2" (IG)	Pocket for thermal sensors
7	G 1/2" (IG)	Pocket for emptying