

Technical data

	operation when directly connected to chimney		operation when connected accumulation mass	
	cupola	hot air exchanger	cupola	adaptor
Energy label	A+	A	A	A
Operating data				
Nominal heat power	8 kW	12 kW	----	----
Efficiency	> 80 %	> 80 %	----	----
Consumption of wood	2,4 kg/h	3,5 kg/h	5,5 kg	5,1 kg
Total heat output of the burning chamber	----	----	22 kW	20 kW
Average heat output / heat accumulation time ⁵	----	----	2,2 kW / 8 h	2 kW / 8 h
Mass flow of flue gas	8 g/s	10 g/s	20 g/s	12,8 g/s
Required chimney pressure	12 Pa	12 Pa	12 Pa	15 Pa
Required amount of combustion air	25 m ³ /h	30 m ³ /h	50 m ³ /h	45 m ³ /h
Average flue gas temperature				
on the output	230 °C	277 °C	382 °C	360 °C
behind 3,6 m of ceramic accumulation system KMS 300 ¹	----	----	180 °C	----
behind accumulation rings (5x acc. ring Ø440mm)	----	----	----	181 °C
Heat distribution				
fireplace insert	65–82 %	65–82 %	40 %	35 %
door glass (single / double)	35 / 18 %	35 / 18 %	35 / 18 %	35 / 18 %
additional accumulation mass	----	----	25–42 %	30–47 %
Information for ventilated builds				
Minimal grill area supply / outgoing	900 / 1050 cm ²	1200 / 1400 cm ²	1200 / 1400 cm ²	1200 / 1400 cm ²
Minimum distance from insulated areas / floor	80 / 0 mm		80 / 0 mm	
Reference insulation ² ceiling / back wall / side wall / floor	120 / 80 / 80 / 0 mm		120 / 80 / 80 / 0 mm	
Calciumsilicate insulation ³ ceiling / back wall / side wall / floor	90 / 60 / 60 / 0 mm		90 / 60 / 60 / 0 mm	
Information for non-ventilated builds (closed grills)				
Minimum radiant area ⁴	suitable		4,5 m ²	
Minimum distance from insulated areas / floor	80 / 20 mm		80 / 20 mm	
Reference insulation ² ceiling / back wall / side wall / floor	160 / 100 / 100 / 20 mm		160 / 100 / 100 / 20 mm	
Calciumsilicate insulation ³ ceiling / back wall / side wall / floor	120 / 75 / 75 / 20 mm		120 / 75 / 75 / 20 mm	
General technical information				
Total weight / lining weight	circa 290 / 104 kg		circa 290 / 104 kg	
Burning chamber dimensions (width x depth)	590 x 315 mm			
Combustion air connection	Ø 125 mm			
Use in non-ventilated accumulation builds according to craft rules	suitable			
Tested according to	EN 13229			
Meets values	1. BlmSchV (Stufe2), 15a BVG, NS 3059			

1 Listed value from testing. For accurate results is evaluation of each system in the Ortnr / KOV program necessary

2 Mineral wool according to AGI-Q 132

3 Example SkamoEnclosure Board 225 kg/m³

4 Depends on accumulation period and material characteristics. Listed values calculated with average specific heat output = approx. 500 W/m²

5 Storage operation, one wood charge for storage duration, with closed construction and efficiency > 80%

HAKA 67/51h

Technical data
Version 09/2023

HAKA 67/51 hot air exchanger vertical / smoke outlet 45°

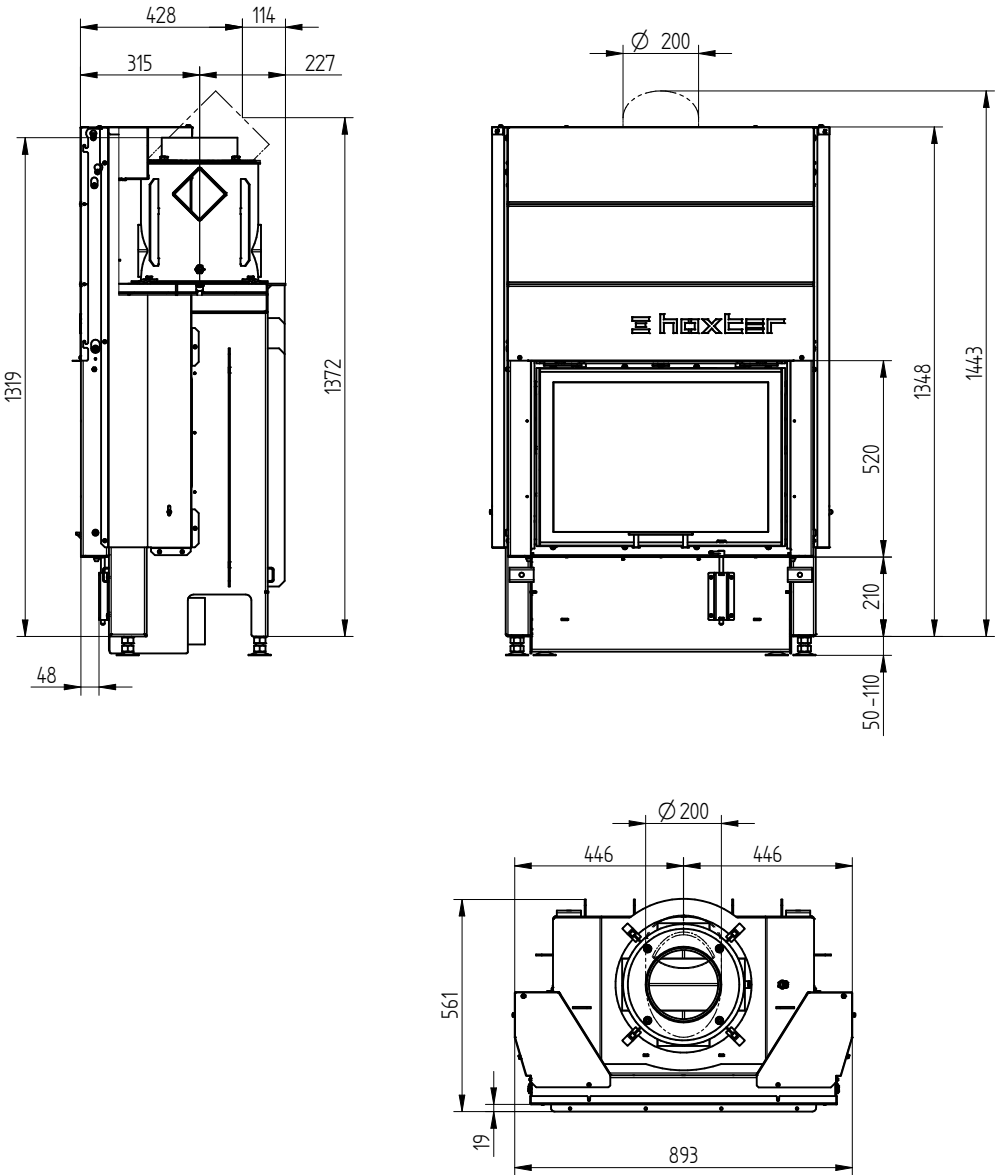

HAKA 67/51h liftdoor cupola

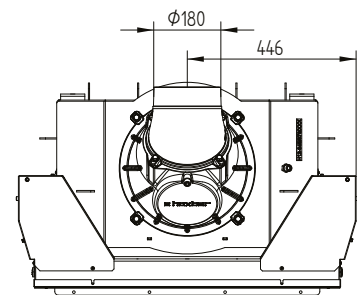
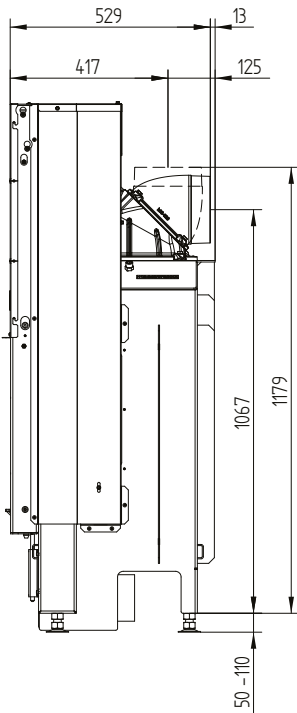

HAKA 67/51h liftdoor accumulation set

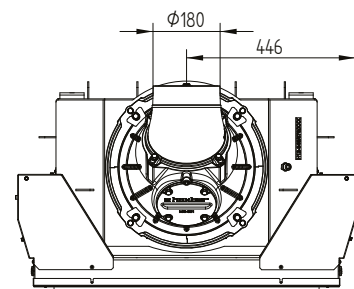
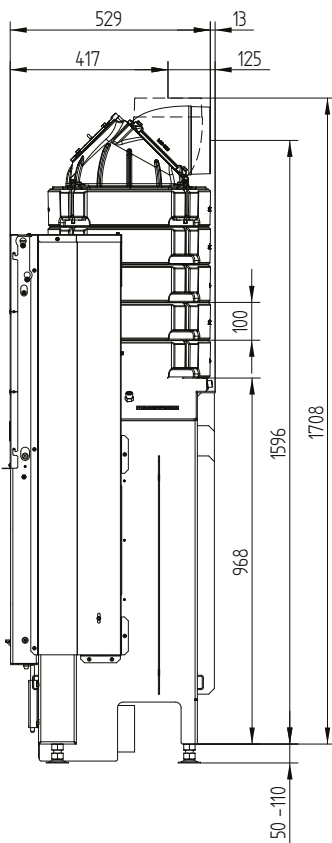

HAKA 67/51h

Technical data
Version 09/2023

Cover frame 67/51h liftdoor 4sides 50 mm 1 x 90° / air inlet

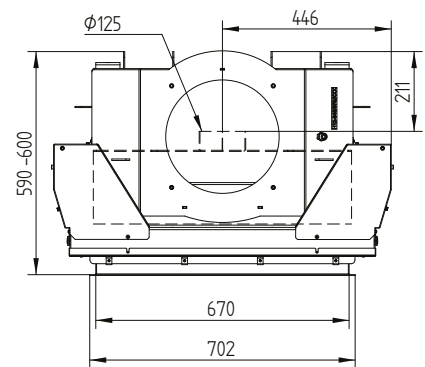
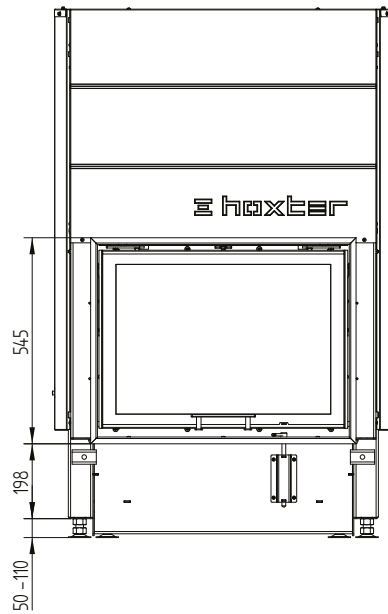
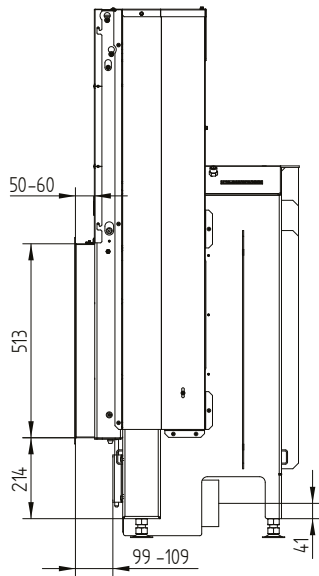

Cover frame 67/51h liftdoor 4sides 80 mm 1 x 90°

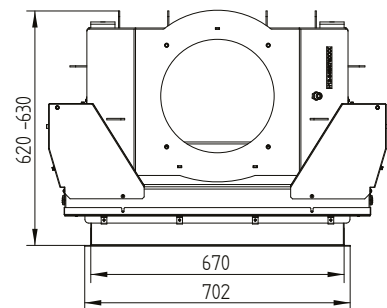
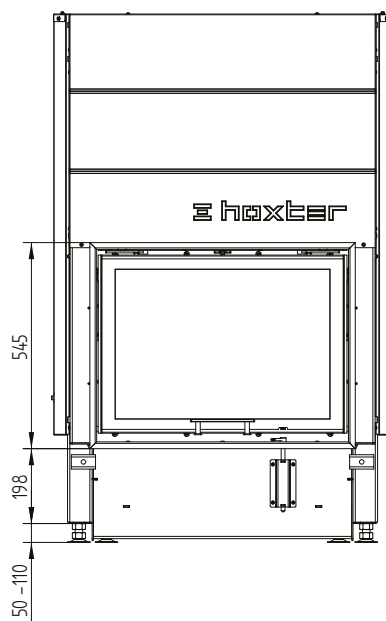
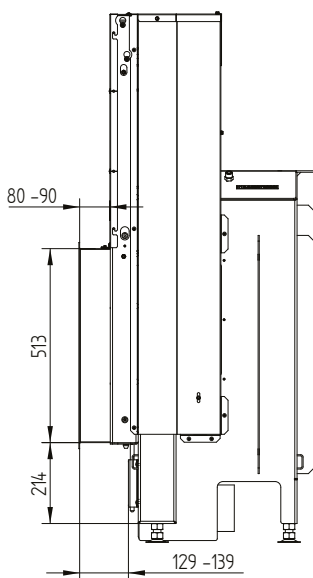

HAKA 67/51h

Technical data
Version 09/2023

Build-on frame 67/51h liftdoor 4sides 50 mm

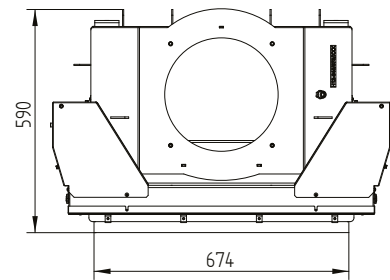
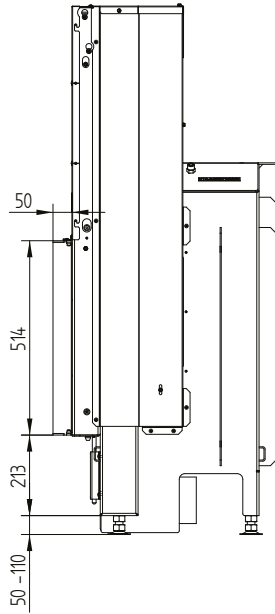

Build-on frame 67/51h liftdoor 4sides 80 mm / feet

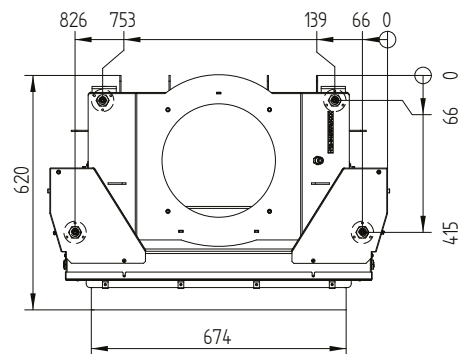
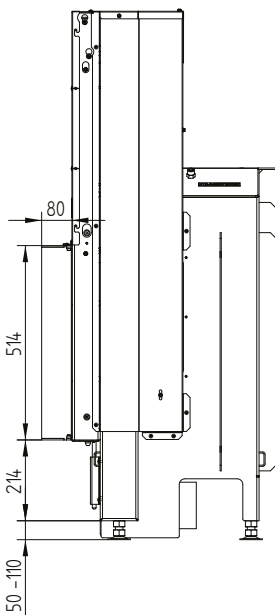

HAKA 67/51h

Technical data
Version 09/2023

Build-on frame 67/51h liftdoor 3sides 80 mm

